

SWTPC Minifloppy Disk Unit

Introduction

The SWTPC minifloppy disk unit is a dual drive, double sided, five-inch disk unit. Double density operation is also available when using the DC-4 disk controller board. The disk unit was designed specifically for the SWTPC 6809 computer. Although the disk unit was completely assembled and tested at the factory, minor reprogramming of the circuit board may be necessary to operate with your particular computer system. It is suggested that this instruction manual be read completely before attempting to use the unit.

Jumper Programming the DC-4 Controller Board

There are five Jumper blocks on the DC-4 controller board that must be properly programmed before the board is installed in the computer. Programming is achieved by plugging the small plastic blocks onto the specified set of programming pins.

- () There are two Jumper locations near the bottom of the board marked 4/16. This Jumper selects the number of address locations assigned to each I/O port. If your computer uses the earlier MP-B or MP-B2 motherboard, RESET switch on RIGHT side of chassis, put the Jumpers in the 4 position. All other computer installations should have the Jumpers in the 16 position.
- () If you will be using the disk unit with a 6800 (not 6809) processor board or a 6809 using FLEX 2.5 or earlier, install the Jumper in the 00 position. All other installations should have the Jumper in the 09 position.
- () Unless specifically noted with a particular piece of software, both the IRQ and FIRQ Jumpers should be in the NORM (OFF) positions or removed completely. Interrupts are presently not used with this board.

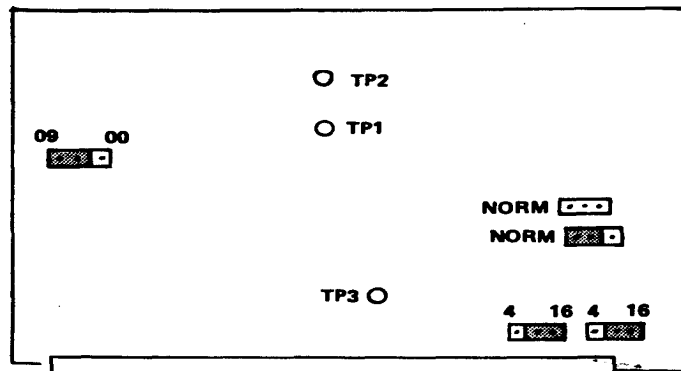

Typical DC-4 Programming Header Locations

Scanned and edited by Michael Holley Oct 23, 2000 holleymj@aol.com

Southwest Technical Products Corporation Document Circa 1978

Installation

- () In order for the MF-69 to work properly with an SWTPC 6800 or 6809 computer with an MP-B or MP-B2 (not MP-B3 or MP-MB) motherboard, one minor modification needs to be made to the motherboard. With a short length of wire connect together each of the two end pins of 30-pin I/O connector row #5. This will connect the #5 port select line to UD3. When connecting the wire, route it around the PC support on the bottom of the board to prevent it from being pinched. Re-install the motherboard when finished. This modification should be done only on MP-B or MP-B2 motherboards.



- () The disk controller board should now be plugged on to I/O slot 6 on computers with MP-B or MP-B2 motherboards or I/O slot 1 on computers with MP-MB or MP-B3 motherboards. The lower edge of the controller board may need to be notched slightly for insertion in certain older chassis.
- () Connect the ribbon cable to the connector on the controller board. Route the cable thru a hole in the rear of the computer or as desired. If the connector supplied on the cable does not have an indexing pin, install the connector so that the cable extends toward the back of the board. The pin 1 side should be nearer the front edge of the board when installed in the computer. When the controller board utilizes a connector that faces the rear of the computer, connect the cable such that the pin 1 side of the cable (banded side) goes toward the 1 marked on the rear mounting panel (toward the top of the computer).

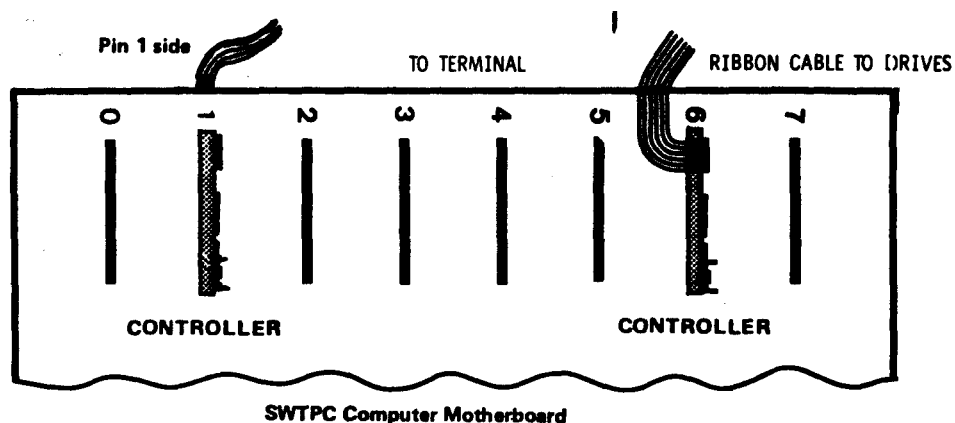

- () Double check to be sure the cable is installed securely on the drives. All cables should be installed as in the following pictorial. By running the cable through the hole in the rear of the chassis the only natural way for the connectors to fit will be the right way, as shown. Be very careful that the cable is installed correctly--incorrect installation can cause damage to the controller and the drives.

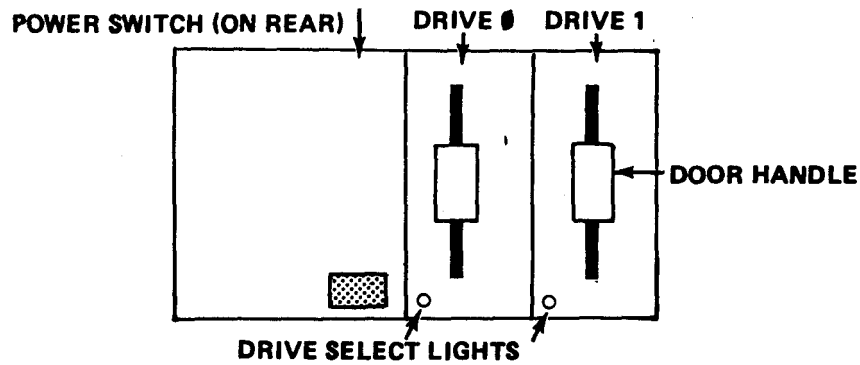

- () This completes the interconnection of the disk and the computer. The disk unit is now ready for checkout/

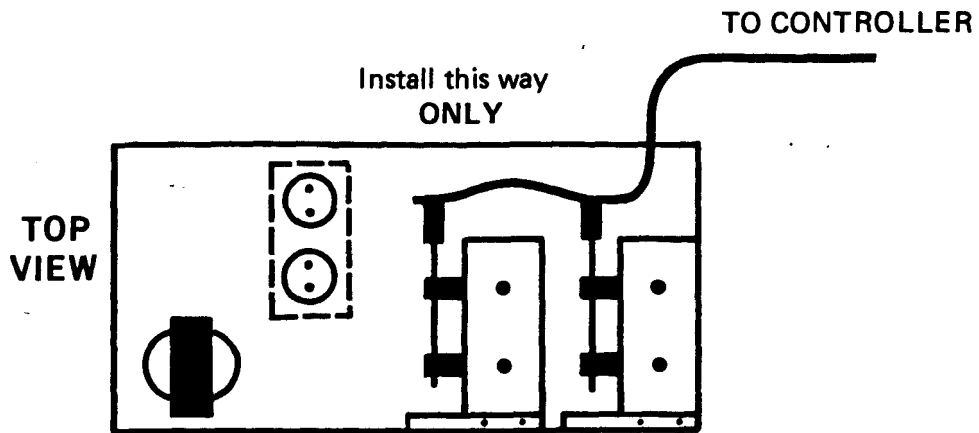

Checkout and Use

- () Be sure that your computer contains enough memory to run the disk operating system that you are using. The software manual supplied with the diskette should specify the amount of memory required.
- () After connecting the disk unit is ready for use. If at any time the disk fails to operate as described, power down the system and recheck all assembly.
- () Power up the disk unit and computer. The power switch for the disk unit is on the back panel. The switch is ON when the paddle on the switch is toward the right as viewed from the front.
- () Write protect the system diskette by placing a small piece of tape around the square notch on the side of the diskette.
- () This completes the interconnection of the disk and the computer. The disk unit is now ready for checkout.

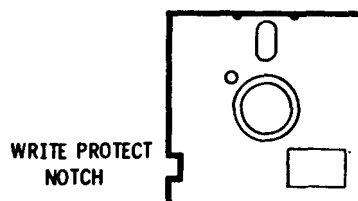

- () Install the diskette into DRIVE 0 (left drive) so that the write protect notch is at the bottom. Be sure to close the door on the drive.
- () Type in the minifloppy disk boot character on your terminal. Check your computer's monitor documentation for the correct character. If the disk unit does not respond, recheck each step of this instruction set then refer to the IN CASE OF PROBLEMS section - of this manual.

Using the Disk Unit

The minifloppy disk unit is designed to be as straightforward and easy to use as possible. There are certain things that the user must be aware of, however, for correct operation.

All memory in the computer must be operational for the disk to operate properly. If any doubt exists, run the memory diagnostics to verify correct operation.

Diskettes should always be inserted with the WRITE PROTECT notch nearest the LED'S on the drive and with the label outward. Having this notch closed with a piece of tape will prevent the disk from being written upon. Leaving the notch open will allow write privileges.

The LED indicators on the front of the drives are drive select lights and are activated only when the particular drive is selected. They are not power indicators.

The disk controller has been designed to select the drive and turn on the drive motors only when necessary. When the computer requests data from the disk, the motors will activate and the correct drive will select. After the information has been retrieved the drive will deselect, and after approximately one minute the motors will turn off.

NOTE: Some versions of the disk operating system will keep a drive selected after an operation is finished. This is a normal condition.

Just like cassette tapes, diskettes are made of magnetic materials and can be erased by stray magnetic fields. Also, it is an excellent idea to back up all important disks on a spare diskette. The following precautions should be followed concerning diskettes:

1. Return the diskette to its storage envelope whenever it is removed from a drive.
2. Keep diskettes away from magnetic fields and from ferromagnetic materials which might become magnetized. Strong magnetic fields can distort recorded data on the disk.
3. Replace storage envelopes when they become worn, cracked or distorted. Envelopes are designed to protect the disk.

4. Do not write on the plastic jacket with a lead pencil or ball point pen. Use a felt tip pen.
5. Heat and contamination from a carelessly dropped ash can damage the disk.
6. Do not exposediskettes to excessive heat or sunlight.
7. Do not touch or attempt to clean the disk surface. Abrasions may cause loss of stored data.

With MP-B and MP-B2 motherboards the disk unit uses the ENABLE line from I/O position 5 as a control line. Care should be exercised when using I/O slot 5 for other devices.

IMPORTANT: Do not power the computer or disk units on or off while diskette are installed in the drives with the doors closed. Doing so may destroy any or all the data stored on the diskette(s).

IN CASE OF PROBLEMS

If your disk unit fails to operate properly we suggest that you first go back and double check all programming and installation steps. An improperly installed or incorrectly programmed board can cause anything from intermittent operation to no operation at all. Also if your system diskette has been damaged the unit will not function properly. If the drive 0 select light does not come on and/or the drive motors do not start, then a hardware problem should be suspected. Service of the minifloppy disk unit should be left to competent technical personnel.

Factory Exchange Service Plan for Assembled Units Only

Southwest Technical Products Corp. provides an exchange program for factory assembled products and product subassemblies which require service. The plan is designed to provide a way of returning systems to operational status as quickly as possible.

All equipment is registered in the plan for a period of six months after installation. After this time an exchange charge is made, if the equipment has not been placed under service contract.

Any article to be returned to the factory must be properly packed and marked with a return address. This should include the name and telephone number of the person requesting the repair. The nature of the problem should also be described as fully as possible.

The serial number of the system from which any subassembly was removed must be supplied with the returned subassembly.

Ship all articles to be returned to the factory prepaid by UPS or insured parcel post. We cannot pick up repairs sent by bus. No COD shipments can be accepted. Articles will be returned prepaid. Upon receipt of a repairable, defective article and payment covering the cost of the article exchange, Southwest Technical Products Corp. will ship a new or equivalent-to-new performance exchange article.

Exchange articles will be placed under a six-month exchange plan at no additional cost, just as new equipment.

EXCHANGE CHARGES

DC-4 Controller board and cable	\$40.00
Power supply	20.00
Disk drive	depends on individual drive

Ship to: Southwest Technical Products Corporation
Repair Dept. - Digital Group
219 W. Rhapsody
San Antonio, Texas 78216

Drive Programming'

Drive programming on assembled units has been done at the factory. The following is supplied for the convenience of technical personnel.

Programming Shugart, Siemens or Wangco Drives.

Carefully remove both drives from their boxes and turn the drives so that the edge connectors are nearest you and so that the belt and pulleys are on the bottom.

- () At the bottom left corner of the board you will notice what looks like an IC made up jumpers in a socket. On one of the drives remove the jumper block with a screwdriver and bend upward (straight) the pins that go to terminals DS2, DS3 and MX. Do not break these pins off. Reinstall the jumper block into the socket. As a double check the jumper block should have pins inserted only in terminals DS1, HS and the unlabeled pin. There should be nothing plugged into the HM position. This drive is now programmed as DRIVE 0.

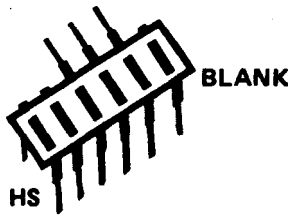

- () On the other drive, bend straight out the pins going to DS1, DS3 and MX. Re-install the jumper so that HS, DS2 and the unlabeled pin have jumper pins installed.
- () Directly above this jumper block you will notice what appears to be a 14-pin IC in a socket. This is not an IC but is an array of pull-up resistors. Carefully remove this array from its socket using a small screwdriver. This array should not be reinstalled. This drive is now programmed as DRIVE 1.

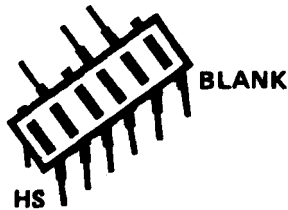

Programming Qume Drives

- () At the bottom left corner of the board you will notice what looks like an IC made up of jumpers in a socket. On one of the drives remove the Jumper block with a screwdriver and bend upward (straight) the pins that go to terminals DS1, DS2, MX, DS3 and HM. Do not break these pins off. Reinstall the Jumper block into the socket. As a double check, the Jumper block should have pins inserted only in terminals DSO and HS. This drive is now programmed as DRIVE 0.

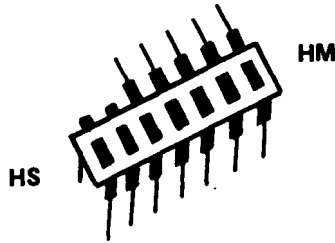

- () On the other drive, bend straight out the pins going to DSO, DS2, MX, DS3 and HM. Re-install the Jumper so that HS and DS1 pins have Jumper pins installed.
- () Directly above this Jumper block you will notice what appears to be a 14-pin IC in a socket. This is not an IC but is an array of pull-up resistors. Carefully remove this array from its socket using a small screwdriver. This array should not be re-installed. This drive is now programmed as DRIVE 1.

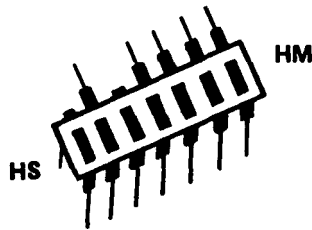

Programming Tandon Disk Drives

Carefully remove both drives from their boxes and turn the drives so that the edge connectors are nearest you and so that the belt and pulleys are on the bottom.

- () At the bottom left corner of the board you will notice what looks like an IC made up of jumpers in a socket. On one of the drives remove the jumper block with a screwdriver and bend straight (upward) the pins shown below. Do not break these pins off. Re-install the jumper block as shown. This drive is now programmed as DRIVE 0.

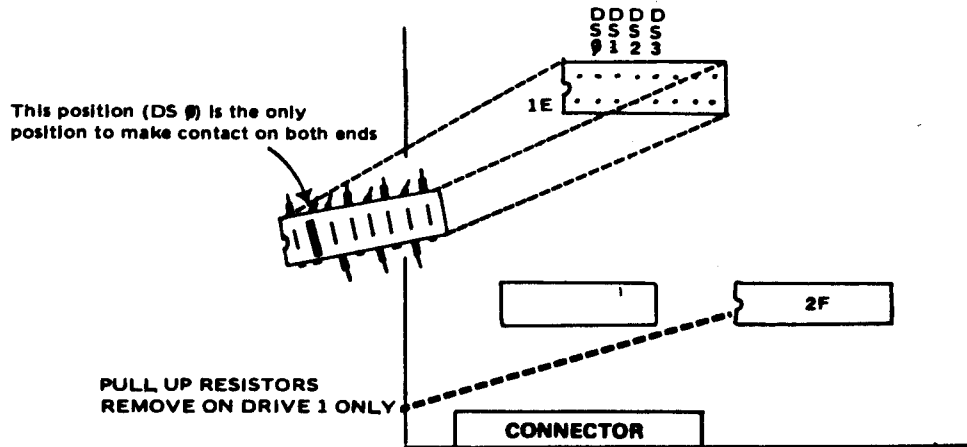

- () On the other drive, bend straight out the pins of its jumper block as shown below. Re-install it as shown.

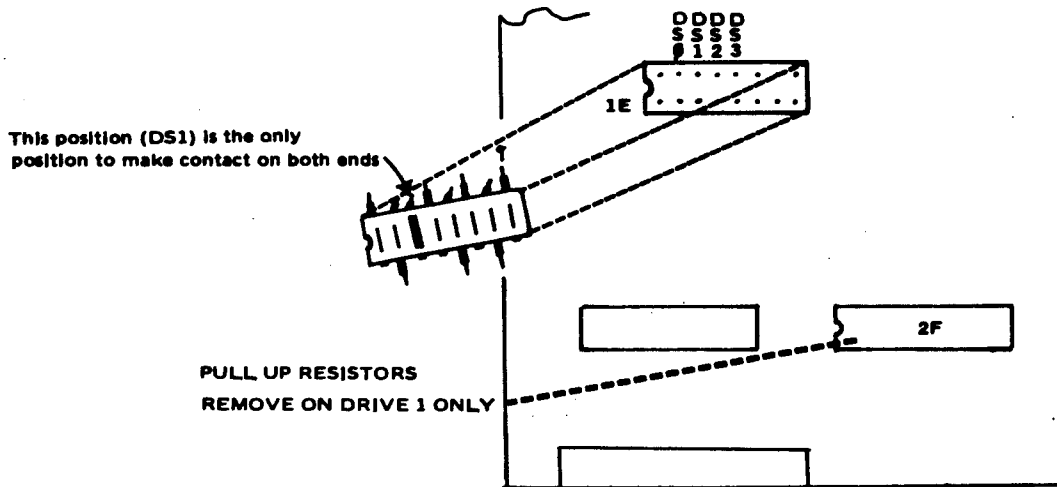

- () Located on this drive below and to the right of the jumper block you will notice what appears to be an IC in a socket. This is an array of pull-up resistors and should be removed. This drive is now programmed as DRIVE 1.

Parts List -- DC-4 Minifloppy Disk Controller

Resistors

___ R1	10K ohm 1/4 watt resistor	___ R10	150K ohm 1/4 watt resistor
___ R2	56K ohm "	___ R11	4.7M ohm " "
___ R3	75K ohm "	___ R12	33 ohm "
___ R4	150 ohm "	___ R13	47K ohm "
___ R5	150 ohm "	___ R14	47K ohm "
___ R6	150 ohm "	___ R15	100K ohm potentiometer
___ R7	150 ohm "	___ R16	50K ohm potentiometer
___ R8	10K ohm "	___ R17	10K ohm 1/4 watt resistor
___ R9	100K ohm "	___ R18	10K ohm

Capacitors

___ *C1	4.7 mfd tantalum electrolytic capacitor	___ *C11	1 mfd electrolytic capacitor
___ *C2	4.7 mfd tantalum electrolytic capacitor	___ C12	0.1 mfd capacitor
___ C3	0.1 mfd capacitor	___ C13	100 pfd capacitor
___ C4	0.1 mfd capacitor	___ C14	0.1 mfd Capacitor
___ C5	0.1 mfd capacitor	___ C15	0.1 mfd Capacitor
___ C6	20 pfd capacitor	___ C16	0.01 mfd film capacitor
___ C7	0.1 mfd capacitor	___ C17	0.33 mfd tantalum capacitor
___ *C8	220 mfd @10 VDC electrolytic capacitor	___ C18	56 pfd poly capacitor
___ C9	0.1 mfd capacitor electrolytic capacitor	___ C19	0.1 mfd capacitor
___ C10	0.01 mfd film capacitor 0.02	___ C20	0.1 mfd capacitor

Integrated Circuits

___ *IC1	1797 disk controller (MOS)	___ *IC9	74LS244 octal buffer
___ *IC2	14541 timer (MOS)	___ *IC10	74LS32 quad OR gate
___ *IC3	74LS123 dual one shot	___ *IC11	74LS132 quad 2 input NAND gate
___ *IC4	74LS244 octal buffer	___ *IC12	4049 hex inverter (MOS)
___ *IC5	74LS139 dual 2 to 4 decoder	___ *IC13	7805 5-volt regulator
___ *IC6	74LS124 VCO	___ *IC14	78L12 12-volt regulator
___ *IC7	74LS240 octal inverter	___ *IC15	1691 Data separator
___ *IC8	74LS175 quad D-flop	___	

Miscellaneous

___ Y1	1.0 MHz crystal
	2.0

* All components flagged with a * must be oriented as shown in the component layout drawing.

Data Separator Adjustment Procedure - DC-4 Disk Controller

Adjustment of the data separator on the DC-4 disk controller board requires some special equipment, such as a good oscilloscope. This adjustment requires some technical ability and should only be done by qualified personnel. This adjustment has been performed at the factory on assembled units.

- 1.) Connect the oscilloscope to test point 1 (TP 1) on the DC-4 board. The ground lead of the scope should be connected to the ground screw on the regulator or other ground on the DC-4 board, not on the ground pin of the connector bus.
- 2.) Adjust potentiometer R15 to obtain a 1.4 volt DC reading. This reading can be verified using a good high impedance DC voltmeter.
- 3.) Connect the oscilloscope to test point 2 (TP 2) on the DC-4 board. Adjust potentiometer R16 for a 2.0 MHz square wave. This measurement can be verified with a good frequency counter.
- 4.) After correct operation of the board is verified, secure each of the potentiometers by using liquid 'silicon rubber cement or equivalent. Do not pour an epoxy or cyanoacrylate type glues down inside the potentiometer as these could ruin the part.

P-30 MF Power Supply

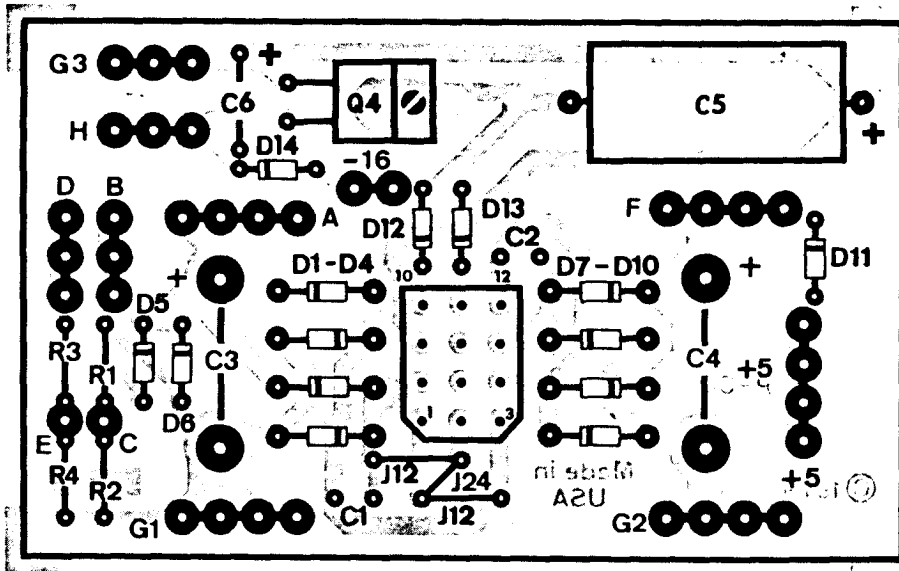

Parts List P-30 MF Power Supply

<u>Resistors</u>		<u>Diodes</u>	
___ R1	243 ohm 1% resistor	___ D1*	1N5402 high current diode
___ R2	2030 ohm 1% resistor	___ D2*	1N5402 high current diode
___ R3	243 ohm 1% resistor	___ D3*	1N5402 high current diode
___ R4	2030 ohm 1% resistor	___ D4*	1N5402 high current diode
		___ D5*	1N4003 diode
		___ D6*	1N4003 diode
		___ D7*	1N5402 high current diode
		___ D8*	1N5402 high current diode
		___ D9*	1N5402 high current diode
		___ D10*	1N5402 high current diode
		___ D11*	1N4003 diode
		___ D12	not used
		___ D14	not used
		___ D15	not used
<u>Capacitors</u>			
___ C1	0.1 mfd capacitor		
___ C2	0.1 mfd capacitor		
___ C3*	20,000 mfd @ 25 VDC electrolytic capacitor		
___ C4*	29,000 mfd @ 25 VDC electrolytic capacitor		
___ C5	not used		
___ C6	not used		
<u>Regulators</u>			
___ Q1*	LM323 +5 VDC regulator	___ Q3*	LM317 adjustable regulator
___ Q2*	LM317 adjustable regulator	___ Q4	not used
<u>Miscellaneous</u>			
___ T1*	Power transformer 50-60 Hz Primary: 120/240 VAC Secondaries: 12 VAC @1.5 A 12 VAC @1.5 A 7 VAC @3A 24 VAC @200 mA	___ Q3*	2 1/2 amp slo-blo fuse
		___ J1	jumper installed
		___ J2	jumper installed

All components flagged with a (*) must be oriented as shown in the component layout drawing and pictorials.

